

SQFlex

Renewable-energy based water-supply systems
50/60 Hz



Contents

Product data

Performance range	page	3
Application	page	4
The SQFlex system	page	4
Type keys	page	5
Pumped liquids	page	5
Curve conditions	page	5
Pump overview	page	6
System overview	page	7

Features and benefits

Dry-running protection	page	8
High efficiency	page	8
Over- and undervoltage protection	page	8
Overload protection	page	9
Overtemperature protection	page	9
Maximum Power Point Tracking (MPPT)	page	9
Wide voltage range	page	9
Reliability	page	10
Installation	page	10
Service	page	10

Application examples

SQFlex Solar	page	11
SQFlex Wind	page	14
SQFlex Combi	page	16
SQFlex system	page	18

System components

CU 200	page	19
Electrical connections, CU 200	page	20
IO 100	page	21
Wiring diagram, IO 100	page	21
IO 101	page	21
Electrical connections, IO 101	page	21
IO 102	page	22
Electrical connections, IO 102	page	22
Generator	page	22

System sizing

Sizing of SQFlex system	page	23
Example	page	23

Performance curves

page	25
------	----

Technical data

Dimensions and weights	page	29
Electrical data	page	29
IO 100 switch box	page	30
IO 101 switch box	page	30
IO 102 breaker box	page	30
CU 200 control unit	page	31
Wiring diagram for pump	page	31
Material specification - helical rotor pump	page	32
Material specification - centrifugal pump	page	33
Material specification - motor	page	34

Product numbers

Complete unit with 2 m cable	page	35
Pump without motor	page	35
Motor without pump	page	35
Submersible drop cables	page	35
IO 100	page	36
IO 101	page	36
CU 200	page	36
IO 102	page	36
Wind turbine H80 Whisper	page	36
Tower kit for H80 Whisper	page	37
Tower installation kit	page	37
Tower pipe selection	page	37

Accessories

Auger / anchor	page	38
Grease	page	38
Level switch	page	38
Anemometer	page	38
Submersible drop cable	page	39
Cable termination kit, type KM	page	39
Cable clips	page	39
Straining wire	page	39
Wire clamp	page	39

Performance range

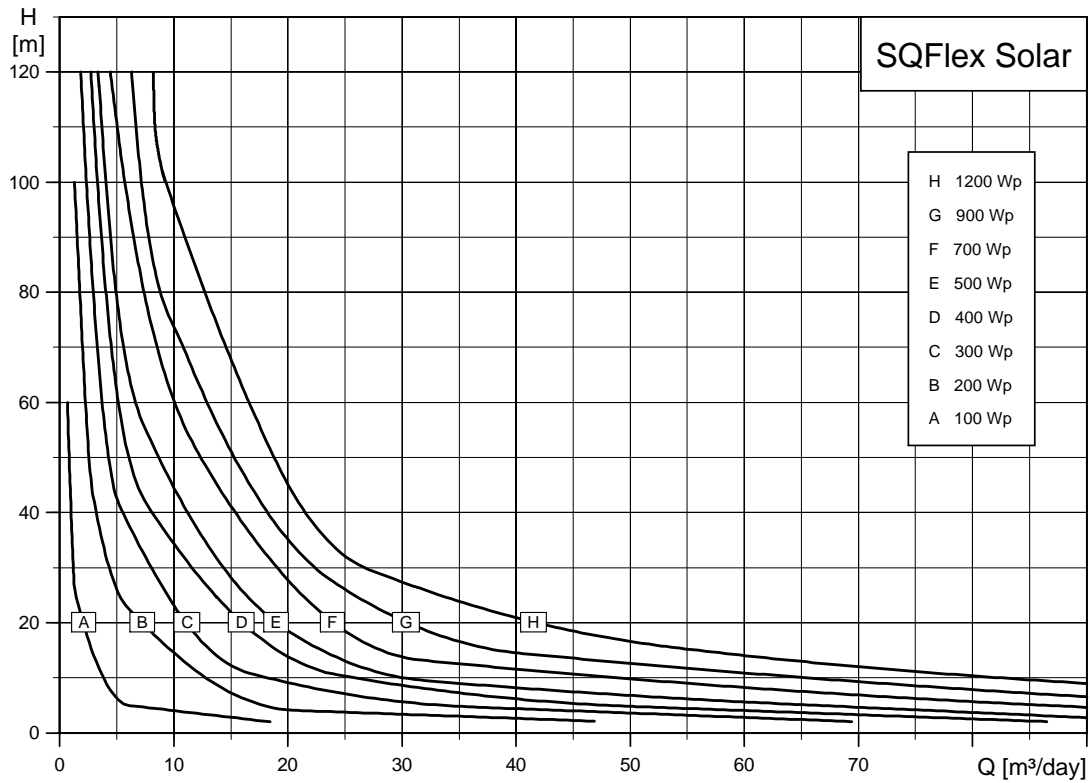

TM02 2337 4101

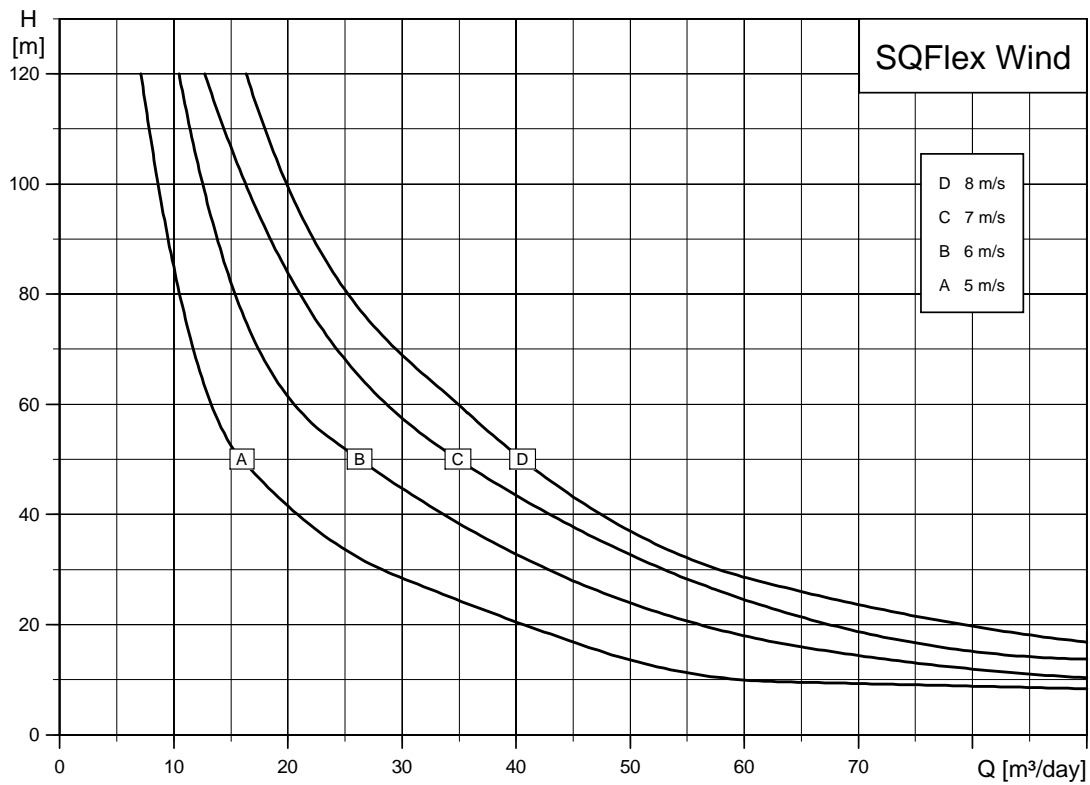

TM02 2411 4201

Note: Do not use the above curves for sizing of the pump.

Application

Being designed for continuous as well as intermittent operation, the SQFlex system is especially suitable for water supply applications in remote locations, such as:

- villages, schools, hospitals, single-family houses etc.
- farms
 - watering of cattle
 - irrigation of fields and greenhouses
- game parks and game farms
 - watering applications
- conservation areas
 - surface water pumping
- Floating pump installations for pumping of water from ponds and lakes.

The SQFlex system

The SQFlex system is a reliable water supply system based on renewable energy sources, such as the sun and the wind energy. The SQFlex system is equipped with the SQF submersible pump.

Very flexible as to its energy supply and performance, the SQFlex system can be combined and adapted to any need according to the conditions on the installation site.

The system components are:

- SQF submersible pump
- CU 200 control unit
- IO 100 and IO 101 switch boxes
- IO 102 breaker box
- energy supply:
 - solar panels
 - wind turbine
 - generator
 - batteries.

Pump

The SQF pump range comprises two pump technologies:

- Helical rotor pump (3") for high heads and small flows.
- Centrifugal pump (4") for low heads and large flows based on the Grundfos SP A pump.

All pump types are available in two material versions:

- SQF is the basic version made of stainless steel EN/DIN 1.4301, AISI 304,
- SQF-N is made of stainless steel EN/DIN 1.4401, AISI 316.

The performance curves below illustrate pump performance for the two pump technologies:

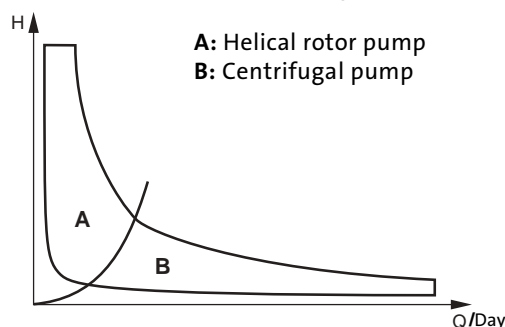

TM02 2425 3901

Motor

The SQFlex motor range comprises only one motor size, the MSF 3 with max. power input (P_1) of 900 W. MSF 3 is a 3" motor. The speed range for the motor is 500-3000 min^{-1} depending on the power input and the load. The motor has been developed especially for the SQFlex system.

The SQFlex motor has three internal limitations,

- max. power consumption (P_1) of 900 W
- max. current of 7 A and
- max. speed of 3000 min^{-1} .

The pump delivers its maximum performance when one of the above limitations is reached.

The motor is available in stainless steel EN/DIN 1.4301 and stainless steel EN/DIN 1.4401.

The motor is designed according to the permanent-magnet principle with built-in electronic unit.

Voltage supply

The motor can be supplied with either AC or DC voltage.

- 30 - 300 VDC, PE
- 1 x 90 - 240 V $-10\%/+6\%$, 50/60 Hz, PE.

IO 100 switch box

The IO 100 is an on/off switch box designed for closing and opening the system voltage supply.

IO 101 switch box

The IO 101 is an on/off switch box for closing and opening the system voltage supply.

The IO 101 is used with SQFlex systems supplied by solar panels and with a generator supply backup.

IO 102 breaker box

The IO 102 is an on/off switch box for closing and opening the system voltage supply.

The IO 102 is used with wind-powered SQFlex systems or with SQFlex systems powered by wind and solar energy.

IO 102 makes it possible to slow down or stop the wind turbine.

CU 200 control unit

The CU 200 control unit is a combined status and control unit for the SQFlex pump system. Furthermore, the CU 200 enables connection of a level switch placed in a water reservoir or similar tank.

Solar modules

Grundfos' solar modules have been developed especially for the SQFlex system. The solar modules are equipped with plugs and sockets enabling easy and simple installation.

Grundfos offers data sheets of solar modules. For further information please contact your local Grundfos Company.

Generator

In case the electricity supply from its primary source of energy is temporarily insufficient, the SQFlex system can be supplied by a generator. The generator can either be diesel or petrol driven.

Batteries

The SQFlex system can be supplied by batteries with a voltage supply of 30 - 300 VDC, minimum current 7A.

Type keys

Type key for helical rotor pumps

Example	SQF	1.2	-2	x
Type range				
Rated flow at 3000 rpm [m ³ /h]				
Number of stages				
Blank = Stainless steel EN/DIN 1.4301, AISI 304				
N = Stainless steel EN/DIN 1.4401, AISI 316				

Type key for centrifugal pumps

Example	SQF	5A	-3	x
Type range				
Rated flow at 3000 rpm [m ³ /h] and pump generation				
Number of stages				
Blank = Stainless steel EN/DIN 1.4301, AISI 304				
N = Stainless steel EN/DIN 1.4401, AISI 316				

Pumped liquids

The SQF pumps are designed for pumping thin, clean, non-aggressive, non-explosive liquids, not containing solid or long-fibred particles larger than sand grains.

Sand content: max. 50 g/m³.

A higher sand content will reduce the pump life considerably due to wear.

pH: 5 - 9
Liquid temperature: 0°C to +40°C

The pump can run at free convection (~ 0 m/s) at max. +40°C.

Salt content

The table below shows the resistance of stainless steel to Cl⁻. The figures in the table are based on a pumped liquid with a pH-value of 4 - 9.

Stainless steel		Cl ⁻ content [ppm]	Liquid temperature [°C]
EN/DIN	AISI		
1.4301	304	0 - 300	< 40
		300 - 500	< 30
1.4401	316	0 - 500	< 40

Curve conditions

The SQFlex Solar performance range shown on page 3 is based on:

- solar radiation on a tilted surface
- H_T = 6 kWh/m² per day
- 20° tilt angle
- ambient temperature: +30°C
- 20° northern latitude
- panel voltage: 120 VDC
- an 11 hour standard solar day.

The SQFlex Wind performance range shown on page 3 is based on:

- average wind speed
- calculations according to Weibull's factor k = 2
- continuous operation over 24 hours.

The performance charts on pages 25 to 28 are based on the following guidelines:

- All curves show mean values.
- The curves must not be used as guarantee curves.
- Typical deviation: +/-15%.
- The measurements were made at a water temperature of +20°C.
- The curves apply to a kinematic viscosity of 1 mm²/s (1 cSt). If the pump is used for liquids with a viscosity higher than that of water, this will reduce the head and increase the power consumption.
- The performance curves are inclusive of inlet and valve losses at the actual speed.
- Supply to pump: 120 VDC.

Pump overview

The SQF pump is available as a complete unit as well as a flexible concept.

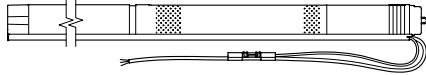
Element	Drawing	Description
SQF pump complete		TM02 2217 3901 SQF pump complete with ... <ul style="list-style-type: none"> • motor • 2.0 m cable with water level electrode, end cover, socket and • cable guard.





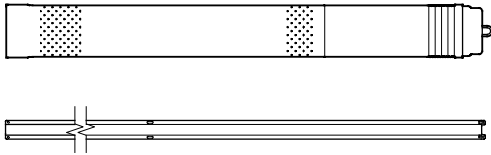
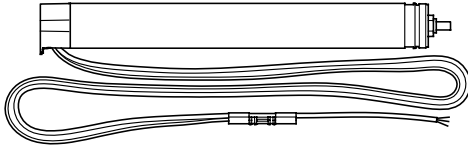



























Flexible concept

Flexible concept means that the pump and motor can be ordered separately.

Element	Drawing	Description
Pump without motor		TM02 2218 3901 - TM02 2221 3901 7 pump types (helical rotor and centrifugal pumps) delivered with cable guard adjusted to the pump. Note: The cable guard for the centrifugal pump types, SQF 5A-3, SQF 5A-6, SQF 8A-3 and SQF 14A-3 is divided in two pieces, one for the pump and one for the motor.
Motor without pump		TM01 2219 3901 MSF 3 motor with 2.0 m cable with water level electrode, end cover and socket.

System overview

The SQFlex system can be used in a number of combinations as shown in the table below.

System consists of the following components						
	Pump	Solar panel ★	Wind turbine	Generator/ supply network	Switch box	CU 200 Control unit	Level switch
SQFlex Solar See page 11.							
SQFlex Solar - with CU 200 control unit and level switch See page 12.							 (**)
SQFlex Solar - with generator as power supply back-up See page 13.							
SQFlex Wind See page 14.							
SQFlex Wind - with CU 200 control unit and level switch See page 15.							 (**)
SQFlex Combi - combination of solar and wind energy See page 16.							
SQFlex Combi - with CU 200 and level switch See page 17.							 (**)
SQFlex system - with generator as power supply See page 18.		(***)	(***)			(***)	(***)

★ For the number of solar modules required, please consult the sizing tool in WinCAPS.

** Can be excluded from the installation.

*** May be a component in the system.

Dry-running protection

The SQF pump is protected against dry running in order to prevent damage to the pump. The dry-running protection is activated by a water level electrode placed on the motor cable 0.3 - 0.6 m above the pump depending on the pump type.

The water level electrode measures the contact resistance to the motor sleeve through the water. When the water level falls below the water level electrode the pump will be cut out. The pump will automatically cut in again 5 min. after the water level is above the water level electrode.

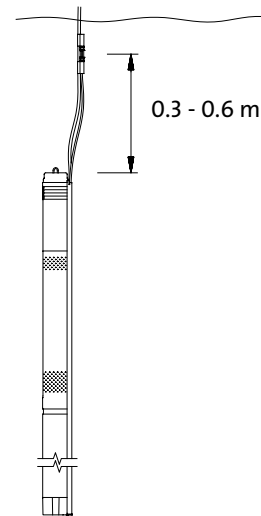

TM02 2436 3901

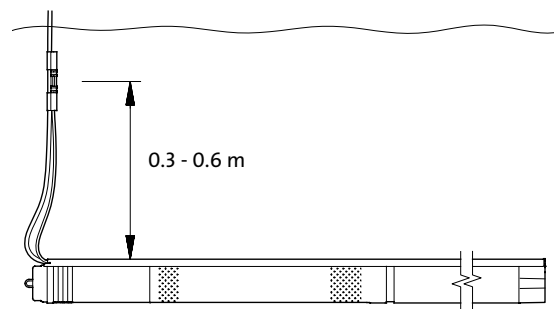

TM02 2435 3901

High efficiency

The MSF 3 motor is a permanent-magnet motor (PM motor) featuring a higher efficiency within the power range compared to a conventional asynchronous motor.

In addition to this the segmented motor stator contributes considerably to the high efficiency.

The MSF 3 motor is furthermore characterised by a high locked-rotor torque even at low power supply.

Over- and undervoltage protection

Overvoltage and undervoltage may occur in case of unstable voltage supply or a faulty installation.

The pump will be cut out if voltage falls outside the permissible voltage range. The motor is automatically cut in again when the voltage is again within the permissible voltage range. Therefore no extra protection relay is needed.

Note: The MSF 3 motor is protected against transients from the the voltage supply according to IEC 60664-1 "overvoltage category III" (4 kV). In areas with high lightning intensity, external lightning protection is recommended.

Overload protection

In case the upper load limit is exceeded, the motor will automatically compensate for this by reducing the speed. If the speed falls below 500 rpm, the motor will be cut out automatically.

The motor will remain cut out for 10 sec. after which period the pump will automatically attempt a restart.

The overload protection prevents burnout of the motor. Consequently, no extra motor protection is required.

Overtemperature protection

A permanent-magnet motor gives off very little heat to its surroundings. In combination with an efficient internal circulation system leading the heat away from the rotor, stator and bearings, this fact ensures optimum operating conditions for the motor.

As an extra protection, the electronic unit has a built-in temperature sensor. When the temperature rises above +85°C, the motor is automatically cut out; when the temperature has dropped to +75°C, the motor is automatically cut in again.

Maximum Power Point Tracking (MPPT)

The built-in electronic unit gives the SQFlex system a number of advantages compared to conventional products. One of these advantages is the built-in microprocessor with MPPT (MPPT = Maximum Power Point Tracking).

Thanks to the MPPT-function, the pump duty point is continuously optimised according to the input power available. MPPT is only available for pumps connected to DC supply.

Wide voltage range

The wide voltage range enables the motor to operate at any voltage from 30-300 VDC or 90-240 VAC. This makes installation and sizing especially easy.

Reliability

The MSF 3 has been developed with a view to high reliability which is achieved through the following features:

- carbon/ceramic bearings
- excellent starting capabilities
- various protection facilities.

Installation

The following features ensure simple installation of the SQF pump:

- low weight ensuring user-friendly handling
- installation in 3", 4" or larger boreholes
- only an on/off switch is needed, which means that no extra motor starter / starter box is necessary, and
- SQF is available with cable with cover and socket.

Note: Horizontal installation requires the water level electrode to be placed min. 0.3 to 0.6 m above the pump to ensure the dry-running protection.

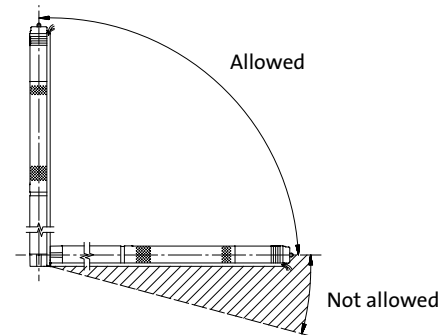

TM02 2246 3901

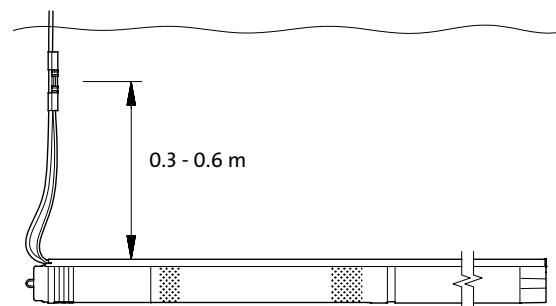

TM02 2435 3901

Service

The modular pump and motor design facilitates installation and service. The cable and the end cover with socket are fitted to the pump with nuts which enable replacement.

SQFlex Solar

The SQFlex Solar system is the simplest of the range of SQFlex systems.

Benefits

- Easy to install
- Maintenance confined to periodic cleaning of the solar panels
- Few and simple components.

The protective circuit incorporated in the motor electronic unit cuts out the pump in case of dry running or similar situations.

By using the IO 100 switch box, the voltage supply to the pump can be closed manually, e.g. when ...

- there is no need for water supply
- the system requires service.

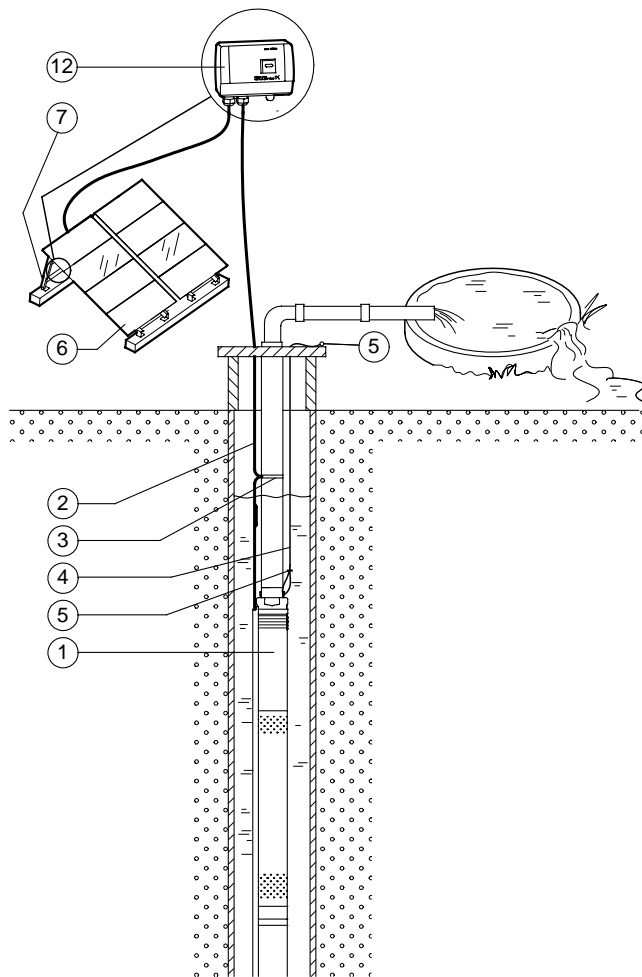

- 1 SQF pump
- 2 Cable
- 3 Cable clips
- 4 Straining wire
- 5 Wire clamp
- 6 Solar panels
- 7 Support structure
- 12 IO 100 switch box

Note: For the number of solar modules required, please consult the Sizing tool.

TW022304 4101

SQFlex Solar

- with CU 200 control unit and level switch

The SQFlex Solar system allows energy from the sun to be stored as water in a reservoir.

SQFlex Solar water supply systems with a water reservoir are used where ...

- there is a need for night-time water supply
- for short periods, the solar energy is insufficient to run the pump
- there is a need for a back-up water source.

Benefits

Combined with the CU 200, the level switch acts as a pump cut-out function when the water reservoir is full.

CU 200 offers indication of ...

- full water reservoir (level switch activated)
- pump operation
- input power.

CU 200 indicates operational stoppage in case of ...

- dry running
- service (see page 19)
- insufficient energy supply.

In addition, the system features ...

- easy installation
- maintenance confined to periodic cleaning of the solar panels.

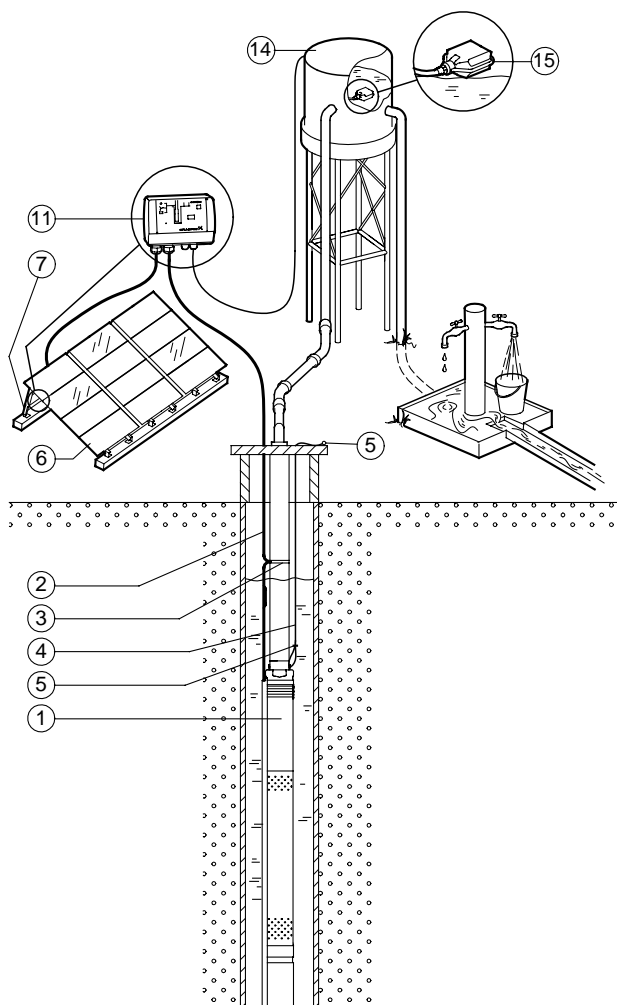

- 1 SQF pump
- 2 Cable
- 3 Cable clips
- 4 Straining wire
- 5 Wire clamp
- 6 Solar panels
- 7 Support structure
- 11 CU 200 control unit
- 14 Water reservoir
- 15 Level switch

Note: For the number of solar modules required, please consult the Sizing tool.

SQFlex Solar

- with generator as power supply back-up

During periods of limited solar energy, the SQFlex Solar water supply system provides a safe supply of water. The system is connected to an external generator as back-up via the IO 101 switch box.

The system enables operation ...

- via generator when ...
 - the energy supply from the solar panels is insufficient
- via solar energy when ...
 - the generator is stopped manually
 - the generator runs out of fuel.

Benefits

- Offers water supply at night or when the solar energy is insufficient
- Easy to install
- Maintenance confined to periodic cleaning of the solar panels
- Few and simple components
- Flexible in terms of energy supply.

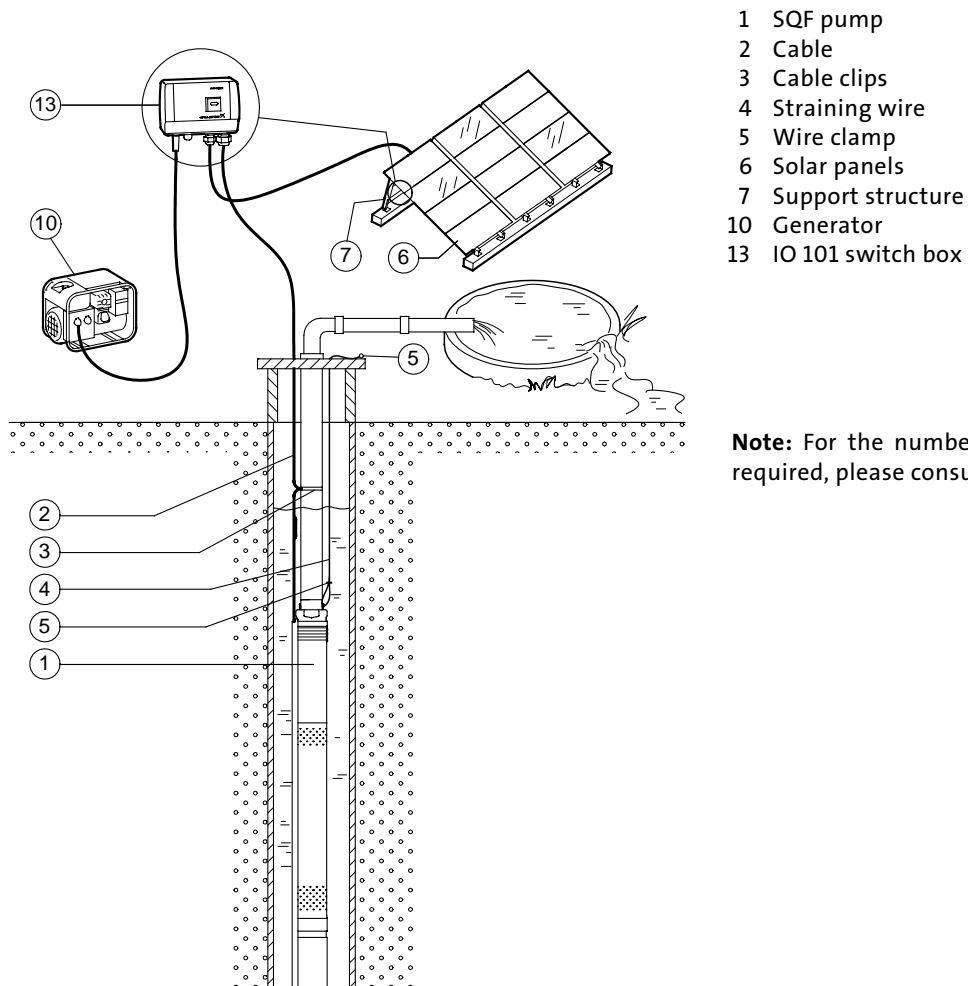

- 1 SQF pump
- 2 Cable
- 3 Cable clips
- 4 Straining wire
- 5 Wire clamp
- 6 Solar panels
- 7 Support structure
- 10 Generator
- 13 IO 101 switch box

Note: For the number of solar modules required, please consult the Sizing tool.

TM02 2309 4101

SQFlex Wind

The SQFlex Wind system is based on wind energy as the only energy source for pump operation.

The system is suitable for installation in areas where the wind is almost constant seen over a period of time.

As the turbine noise level increases with the wind speed, siting of the wind turbine near a residence is not recommended.

The IO 102 breaker box makes it possible to brake the wind turbine when ...

- there is no need for water supply
- the system requires service.

Benefits

- Easy to install
- A minimum of maintenance required
- Few and simple components.

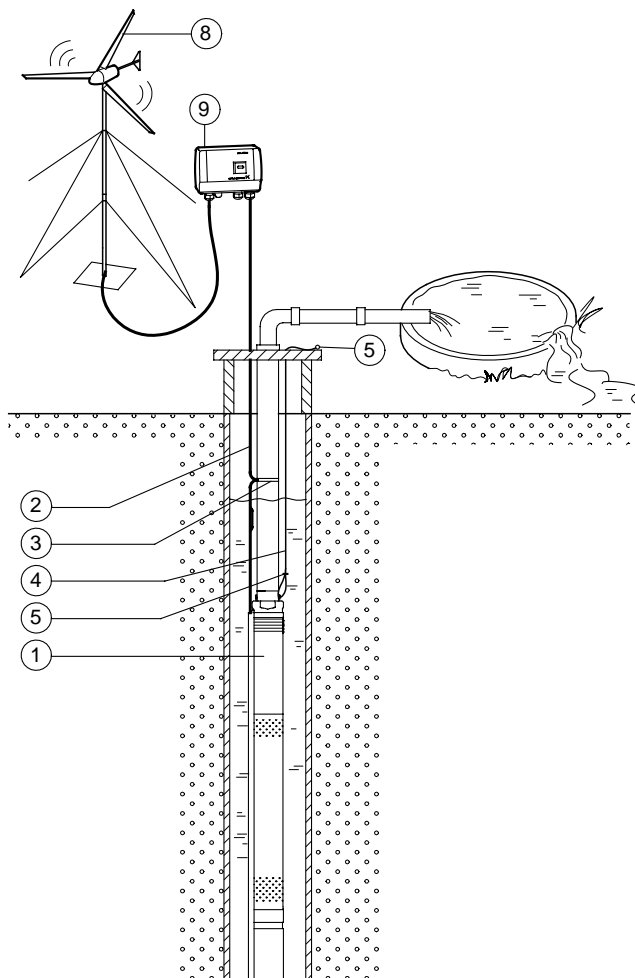

- 1 SQF pump
- 2 Cable
- 3 Cable clips
- 4 Straining wire
- 5 Wire clamp
- 8 Wind turbine
- 9 IO 102 breaker box

TM02 2306 4101

SQFlex Wind

- with CU 200 control unit and level switch

The SQFlex Wind system allows energy from the wind to be stored as water in a reservoir.

SQFlex Wind water supply systems with a water reservoir are used where ...

- for short periods, the wind energy is insufficient to run the pump
- there is a need for a back-up water source.

As the turbine noise level increases with the wind speed, siting of the wind turbine near a residence is not recommended.

Benefits

Combined with the CU 200, the level switch acts as a pump cut out function when the water reservoir is full.

CU 200 offers indication of ...

- full water reservoir (level switch activated)
- pump operation
- input power.

CU 200 indicates operational stoppage in case of ...

- dry running
- service (see page 19)
- insufficient energy supply.

The IO 102 breaker box makes it possible to interrupt the supply voltage in the system and to slow down or stop the wind turbine when ...

- there is no need for water supply
- the system requires service.

In addition, the system features ...

- easy installation
- a minimum of maintenance.

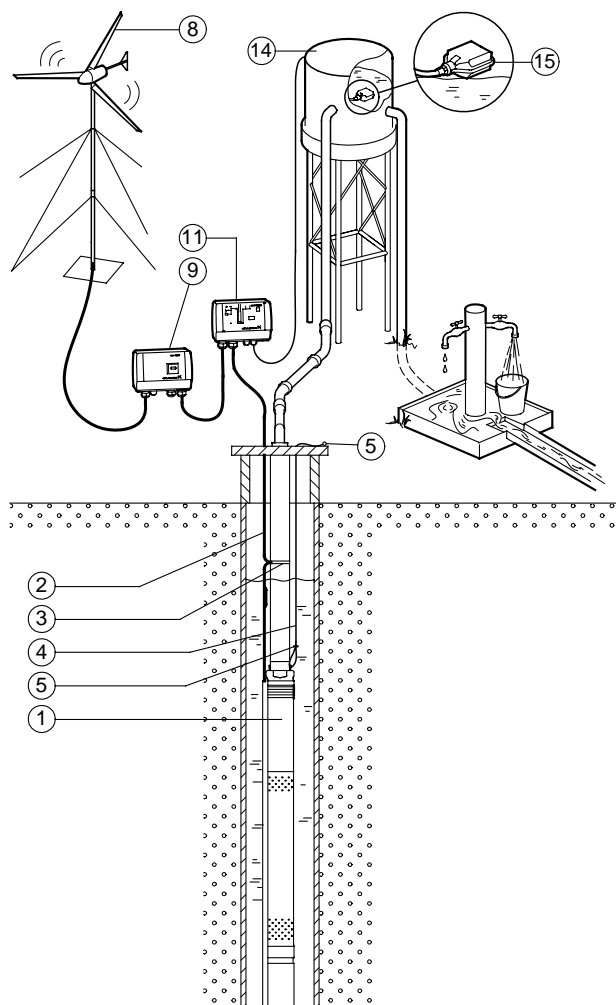

- 1 SQF pump
- 2 Cable
- 3 Cable clips
- 4 Straining wire
- 5 Wire clamp
- 8 Wind turbine
- 9 IO 102 breaker box
- 11 CU 200 control unit
- 14 Water reservoir
- 15 Level switch

TM02 2308 4101

SQFlex Combi

- combination of solar and wind energy

The SQFlex Combi water supply system is ideal in areas where the solar or wind energy is sufficient to run the pump.

The energy supply to the pump is a combination of solar and wind energy.

As the turbine noise level increases with the wind speed, siting of the wind turbine near a residence is not recommended.

Benefits

- Offers water supply at night or when the solar energy is insufficient
- Easy to install
- Maintenance confined to periodic cleaning of the solar panels
- Few and simple components.

The IO 102 breaker box makes it possible to interrupt the supply voltage in the system and to slow down or stop the wind turbine when ...

- there is no need for water supply
- the system requires service.

In addition, the system features ...

- easy installation
- a minimum of maintenance.

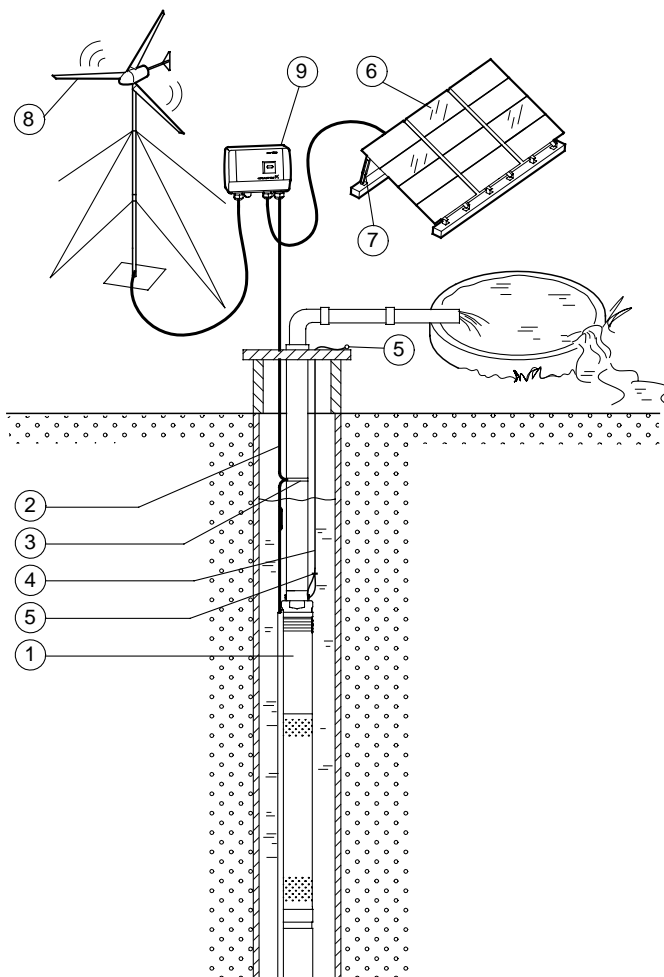

- 1 SQF pump
- 2 Cable
- 3 Cable clips
- 4 Straining wire
- 5 Wire clamp
- 6 Solar panels
- 7 Support structure
- 8 Wind turbine
- 9 IO 102 breaker box

Note: For the number of solar modules required, please consult the Sizing tool.

TM02 2307 4101

SQFlex Combi

- with CU 200 and level switch

The SQFlex Combi system allows solar and wind energy to be stored as water in a reservoir.

SQFlex Combi water supply systems with a water reservoir are used where ...

- for short periods, the solar or wind energy is insufficient to run the pump
- there is a need for a back-up water source.

As the turbine noise level increases with the wind speed, siting of the wind turbine near a residence is not recommended.

Benefits

Combined with the CU 200, the level switch acts as a pump cut-out function when the water reservoir is full.

CU 200 offers indication of ...

- full water reservoir (level switch activated)
- pump operation
- input power.

CU 200 indicates operational stoppage in case of ...

- dry running
- service (see page 19)
- insufficient energy supply.

The IO 102 breaker box makes it possible to interrupt the supply voltage in the system and to slow down or stop the wind turbine when ...

- there is no need for water supply
- the system requires service.

In addition, the system features ...

- easy installation
- a minimum of maintenance.

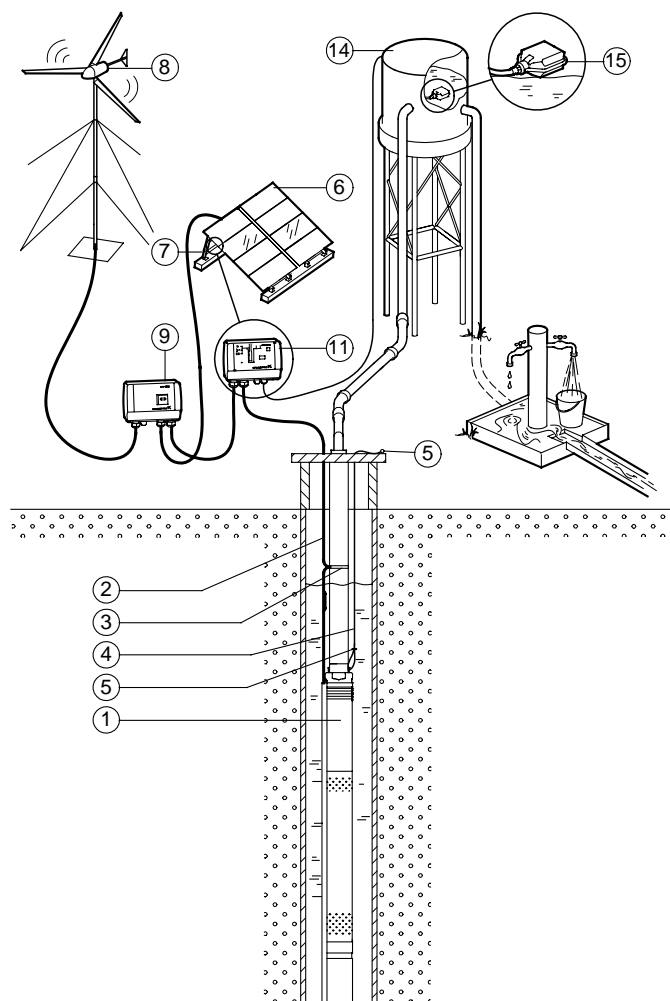

- 1 SQF pump
- 2 Cable
- 3 Cable clips
- 4 Straining wire
- 5 Wire clamp
- 6 Solar panels
- 7 Support structure
- 8 Wind turbine
- 9 IO 102 breaker box
- 11 CU 200 control unit
- 14 Water reservoir
- 15 Level switch

Note: For the number of solar modules required, please consult the Sizing tool in WinCAPS.

SQFlex system

- with generator as power supply

The SQFlex water supply system is connected to a generator, which can be diesel or petrol driven.

Benefits

- Offers water supply 24 hours a day independent of the weather.
- Easy installation.
- A minimum of maintenance required.
- Few and simple components.

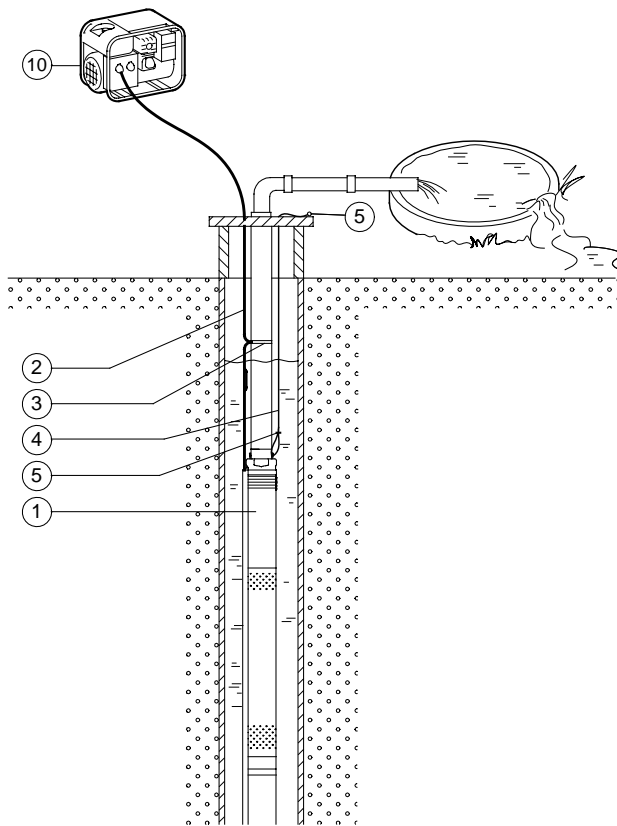

- 1 SQF pump
- 2 Cable
- 3 Cable clips
- 4 Straining wire
- 5 Wire clamp
- 10 Generator

TM02 2311 4101

CU 200

The CU 200 control unit is a combined status, control and communication unit especially developed for the SQFlex system. Furthermore, the CU 200 enables connection of a level switch.

The CU 200 incorporates cable entries for ...

- power supply connection (pos. 6),
- pump connection (pos. 7),
- earth connection (pos. 8),
- level switch connection (pos. 9).

(The position numbers shown in brackets refer to the drawing to the right).

Communication between the CU 200 and the pump takes place via the pump power supply cable. This is called mains borne signalling (or Power Line Communication), and this principle means that no extra cables between the CU 200 and the pump are required.

It is possible to start, stop and reset the pump by means of the on/off button (pos. 1).

The CU 200 control unit offers:

- System monitoring
- Alarm indication.

The following indications allow the operation of the pump to be monitored:

- Water reservoir is full (level switch) (pos. 2)
- Pump is running (pos. 3)
- Input power (pos. 11).

The CU 200 offers the following alarm indications:

- Dry running (pos. 10)
- Service needed (pos. 5) in case of:
 - No contact to pump
 - Overvoltage
 - Overtemperature
 - Overload.

In addition, the CU 200 shows the symbols of the energy supply options (pos. 4).

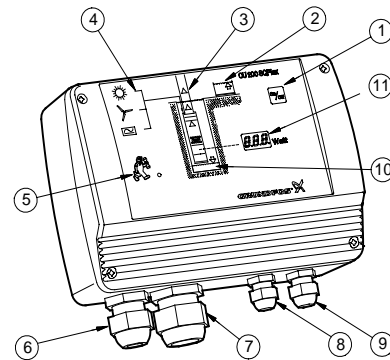

TM02 2325 41.01

Dimensions, CU 200

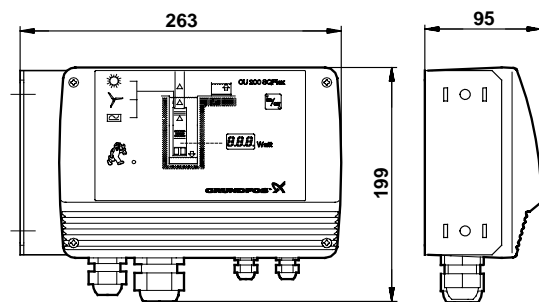

TM02 2323 4003

Dimensions stated in mm.

Electrical connections, CU 200

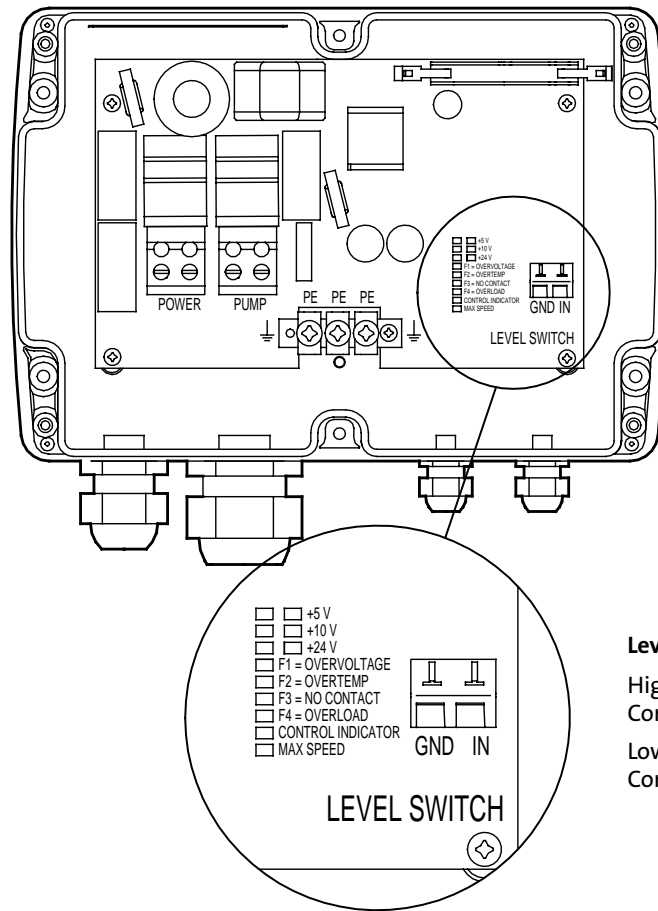

Level switch input:

High water level:
Contact is closed

Low water level:
Contact is open

TM02.2515-4401

IO 100

The IO 100 switch box is designed specifically for solar powered SQFlex systems.

The IO 100 enables manual starting and stopping of the pump in an SQFlex Solar system and functions as a connection box joining all necessary cables.

The dimensions and wiring diagram of IO 100 are shown below.

Dimensions, IO 100

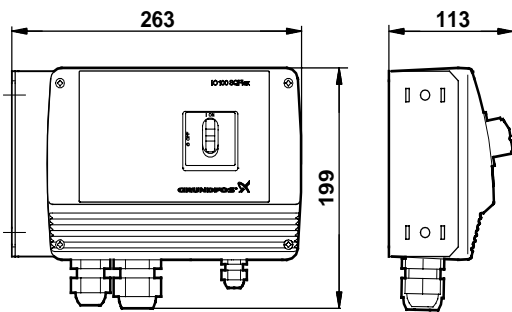

TM02 2545 4003

Dimensions stated in mm.

Wiring diagram, IO 100

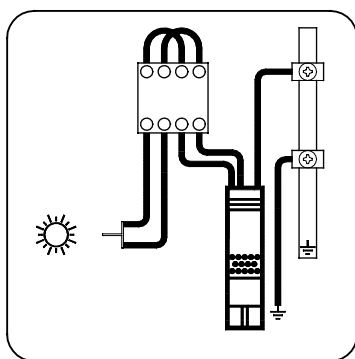

TM02 4058 4701

IO 101

The IO 101 switch box is designed specifically for solar powered SQFlex systems.

The IO 101 enables the connection of a generator supply back-up in case of insufficient solar radiation. The switching between solar power and generator must be made manually.

In case the generator is stopped manually or runs out of fuel, the IO 101 will automatically switch to the solar energy supply.

The IO 101 functions as a connection box joining all necessary cables.

The dimensions and electrical connections of IO 101 are shown below.

Dimensions, IO 101

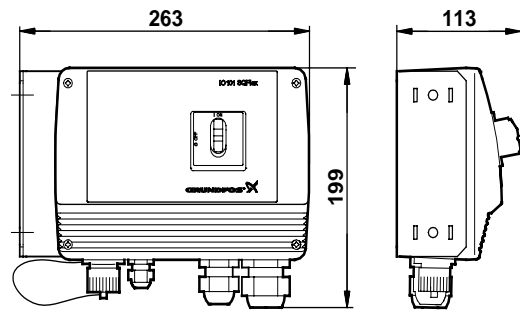

TM02 2546 4003

Dimensions stated in mm.

Electrical connections, IO 101

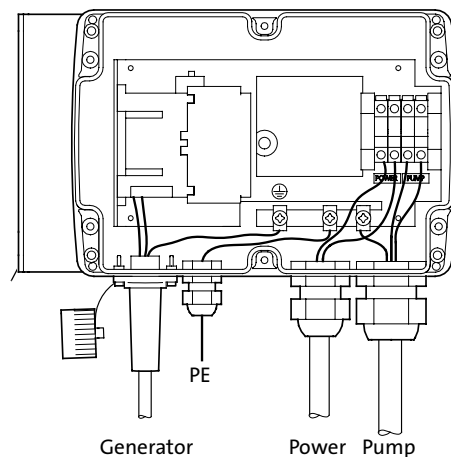

TM02 4162 5001

IO 102

The IO 102 breaker box is designed specifically for wind powered SQFlex systems.

The IO 102 enables manual starting and stopping of the pump in an SQFlex Wind system and an SQFlex Combi system.

The on/off switch has a built-in electrical brake for the turbine. When the switch is in the "off" position, the turbine stops or slows down.

The IO 102 rectifies the three-phase AC voltage from the wind turbine into DC voltage. Furthermore, the IO 102 enables the combination of wind energy from the wind turbine and solar energy from the solar panel.

At the same time, the IO 102 also functions as a connection box joining all necessary cables.

Dimensions and wiring diagram of the IO 102 are shown below.

Dimensions, IO 102

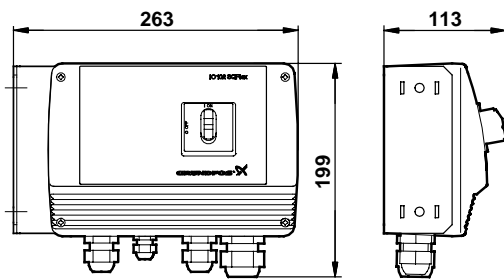

TM02 4232 4003

Dimensions stated in mm.

Electrical connections, IO 102

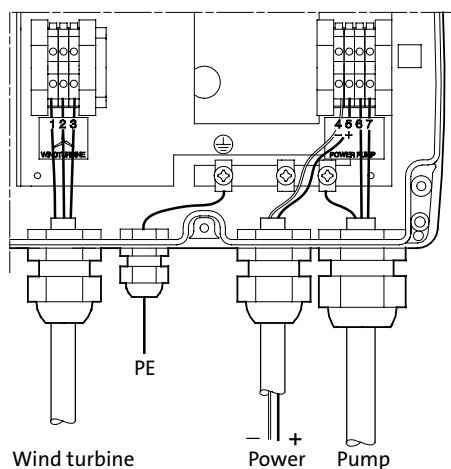

TM02 4312 0502

Generator

The generator can be either diesel or petrol driven.

The generator must be running steadily before the pump is cut in.

Sizing of SQFlex system

Grundfos has developed a PC-based sizing tool enabling the sizing of SQFlex systems.

The sizing tool is also available in a paper version. The PC-based sizing tool is integrated in WinCAPS and covers both solar and wind powered systems. The paper version covers both solar powered and wind powered systems.

The following three parameters must be known for the sizing of the optimum SQFlex system:

- installation location
- max. head required and
- quantity of water required.

With a view to the sizing of a correct solar powered SQFlex system the world has been divided into six regions:

- North America
- South America
- Australia/New Zealand
- Asia/Pacific
- Southern Africa
- Europe/Middle East/Northern Africa.

Each region is divided into a number of zones according to the solar radiation in kWh/m² per day.

The following example shows the sizing of a solar powered SQFlex system using the paper version of the sizing tool.

For the sizing of a wind powered SQFlex system, please refer to the WinCAPS version.

Example

Conditions:

- installation location: Johannesburg, South Africa
- required head: 70 m
- quantity of water required: 5.5 m³/day

Proceed as follows:

1. Find Johannesburg on the map.
The map shows that Johannesburg is located in solar radiation zone K, and the recommended tilt angle of the solar panel is 30°.
2. Go to the sizing table and find zone K and tilt angle 30°.
3. Find the required head (A) and the required flow (B) and read the recommended SQF pump type (C), number of solar modules (D) and the output power of the solar modules (E).

SQFlex system configuration:

Pump: SQF 1.2-2

Number of solar modules: 8

Power: 50 Wp x 8 = 400 Wp.

Finally, determine the material variant on the basis of the chemical composition of the pumped liquid.

Southern Africa (January)

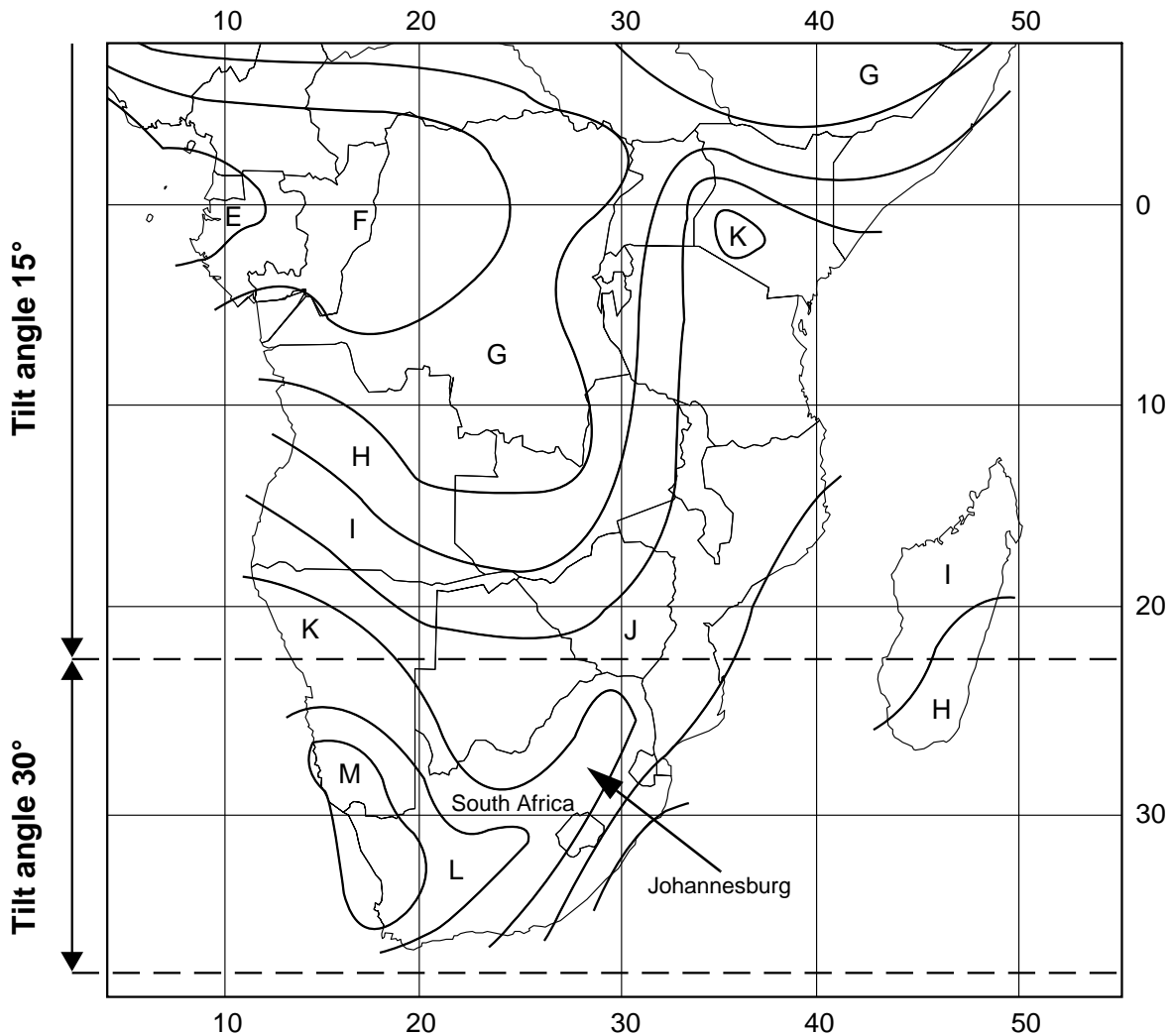

TM02.2418.4201

Sizing table

Zone	Solar radiation	Required head [m]											No. of 50 Wp modules	Power [Wp]		
		5	10	20	30	40	50	60	70 (A)	80	90	100			110	120
Zone K - tilt angle 30°	7.3 kWh/m ² per day	Required flow [m ³ /day]											4	200		
		26.7	13.6	9.8	5.6	3.8	3.0	2.8	2.5	2.2	2.0	1.7			1.4	1.1
		SQF 8A-3		SQF 2.5-2			SQF 1.2-2		SQF 0.6-2							
		60.5	29.8	19.0	13.9	10.0	7.5	6.4	5.5	4.7	4.1	3.9	3.6	3.3		
		SQF 14A-3		SQF 5A-3		SQF 2.5-2		SQF 1.2-2 (C)			SQF 0.6-2			8 (D)		400 (E)
		87.2	47.2	23.5	19.0	15.9	12.8	10.3	8.1	7.4	6.6	6.0	5.2	4.4		
		SQF 14A-3		SQF 5A-3		SQF 2.5-2			SQF 1.2-2				SQF 0.6-2		12	600
		107	67.9	33.5	21.1	18.7	16.6	14.2	11.6	9.1	8.0	7.4	7.0	6.4		
SQF 14A-3		SQF 5A-6		SQF 2.5-2			SQF 1.2-2				16		800			
124	83.6	42.6	26.4	20.2	18.5	16.4	14.1	12.2	9.7	8.4	7.9	7.3				
SQF 14A-3		SQF 5A-6		SQF 2.5-2			SQF 1.2-2				20		1000			

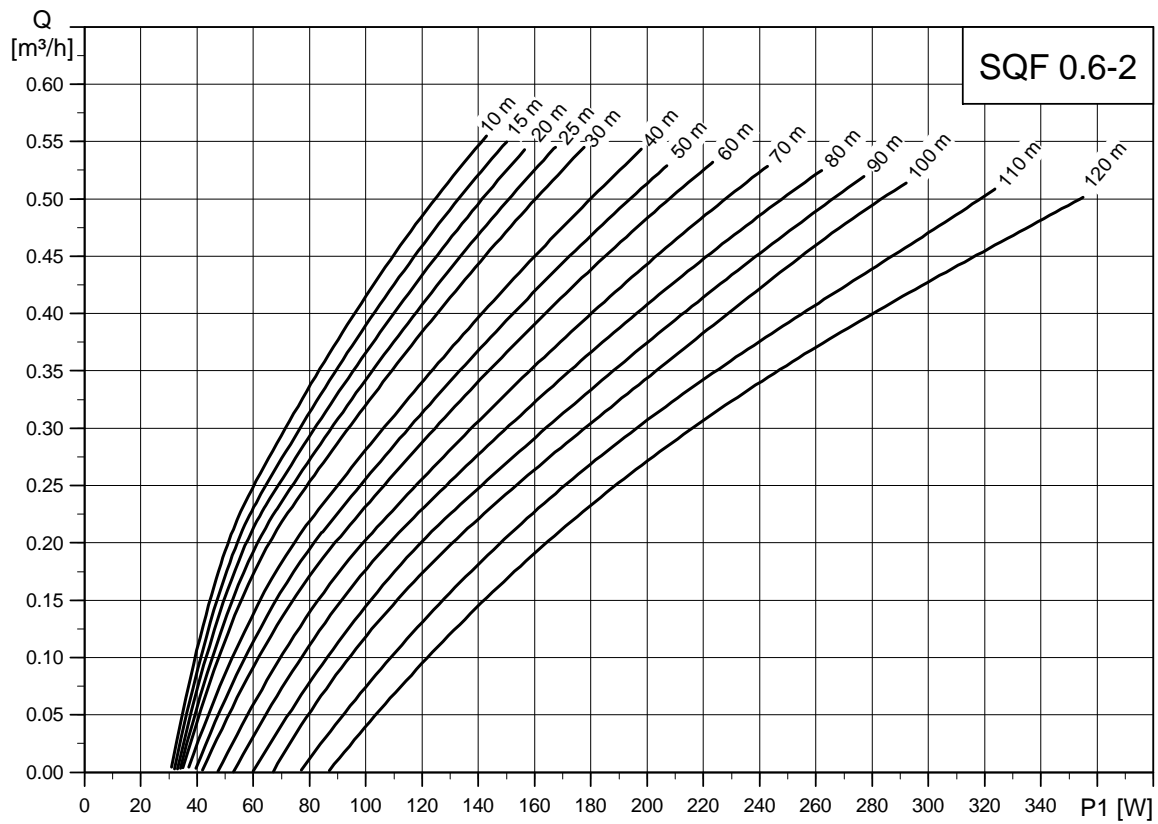

TM02 2338 4101

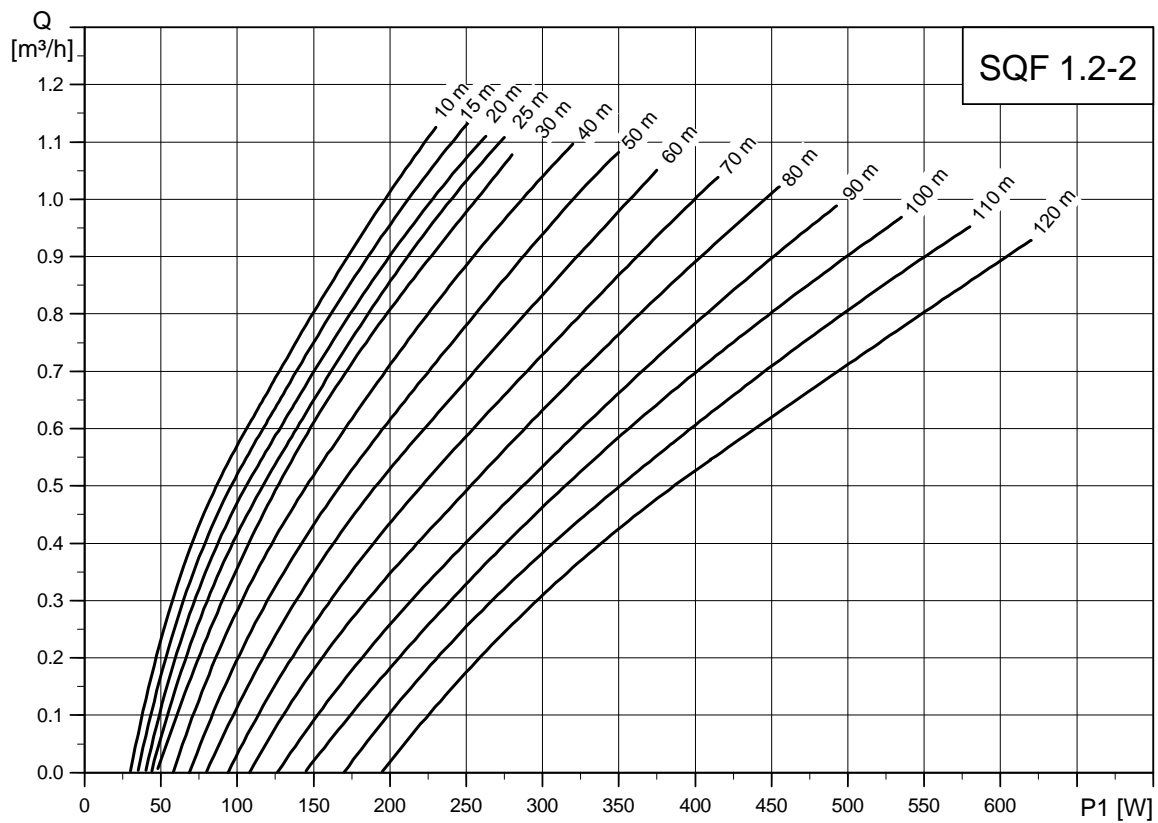

TM02 2339 4101

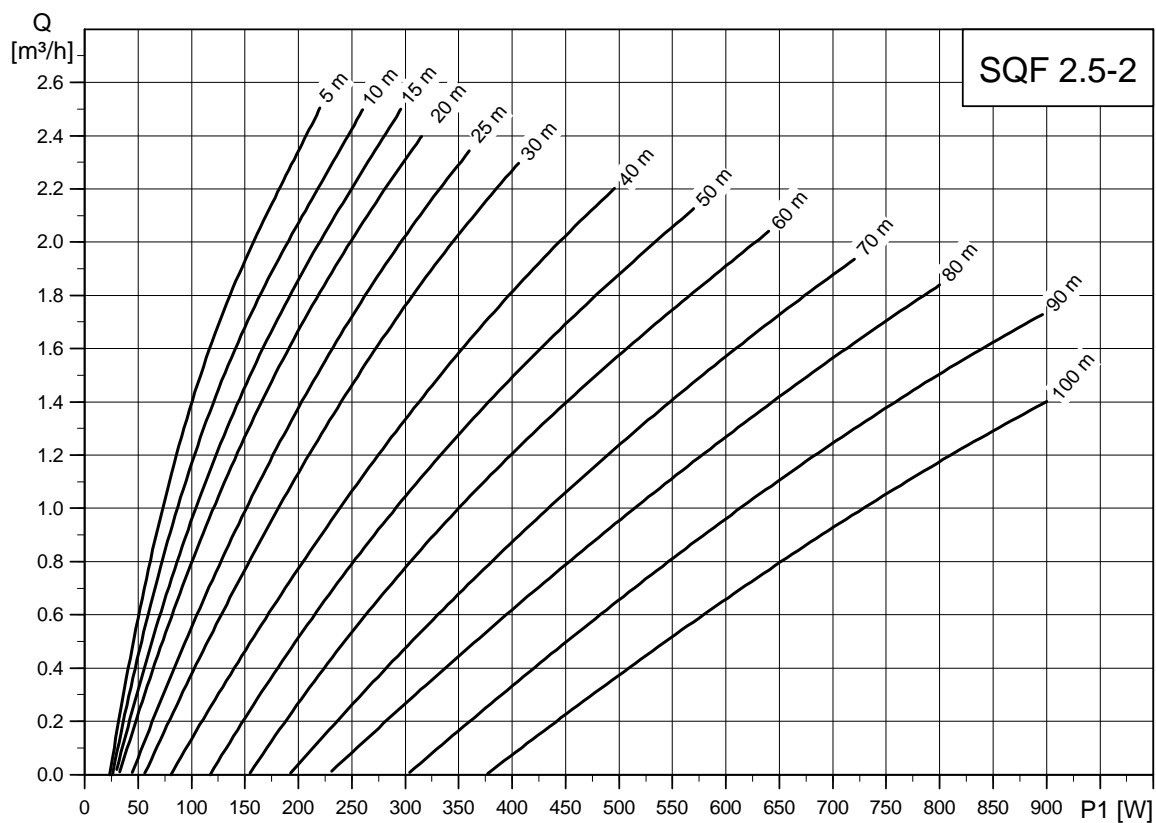

TM02 2340 4101

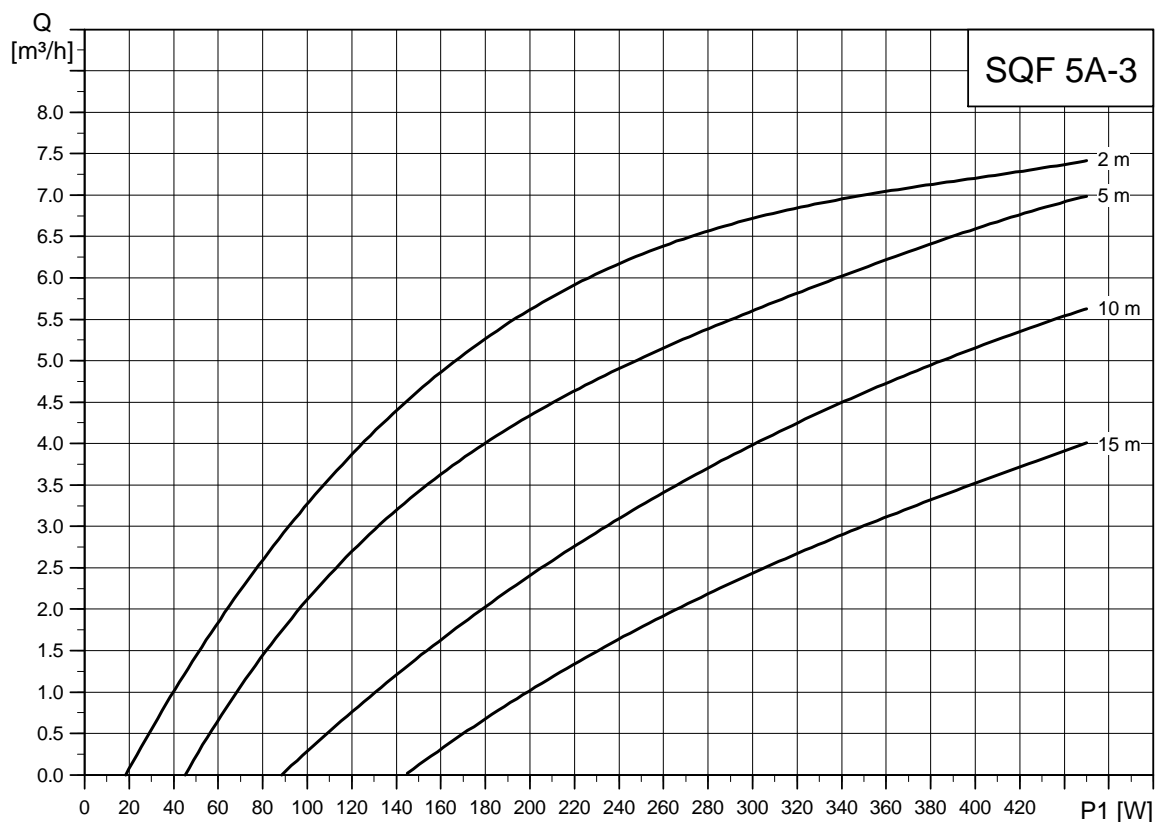

TM02 2341 4101

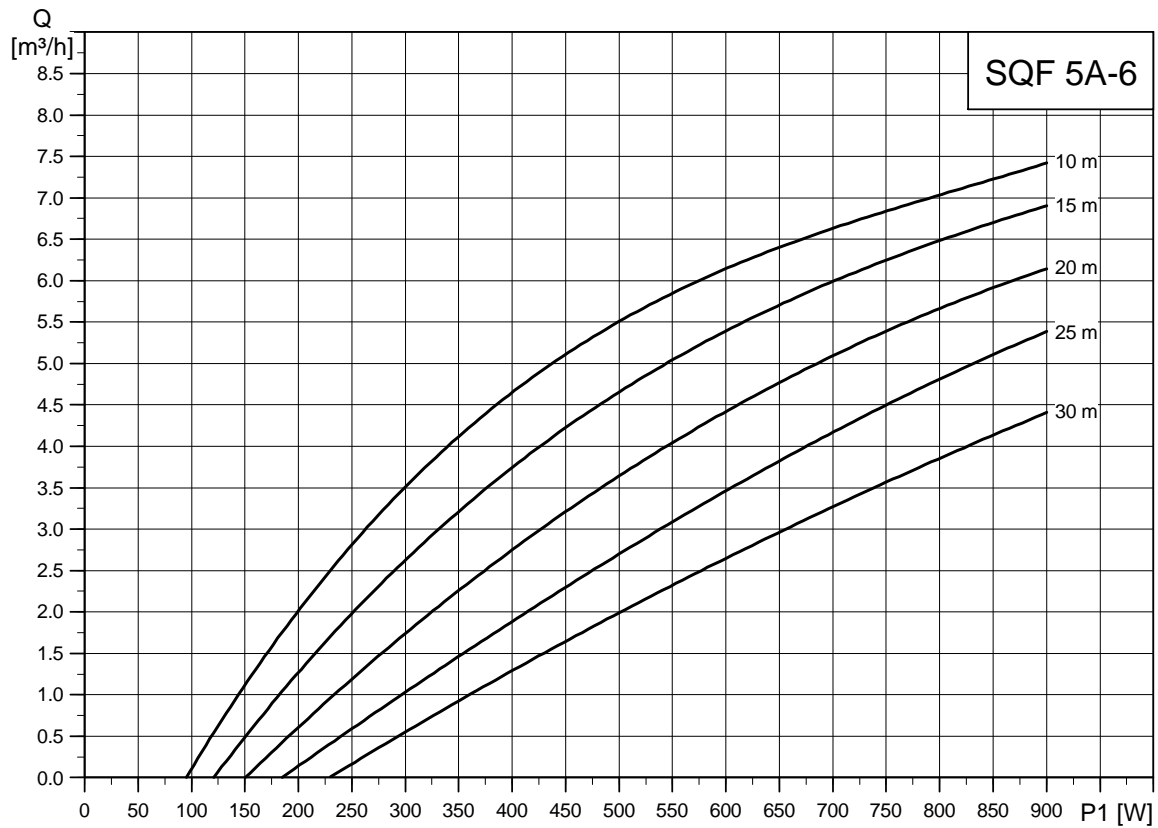

TM02 2342 4101

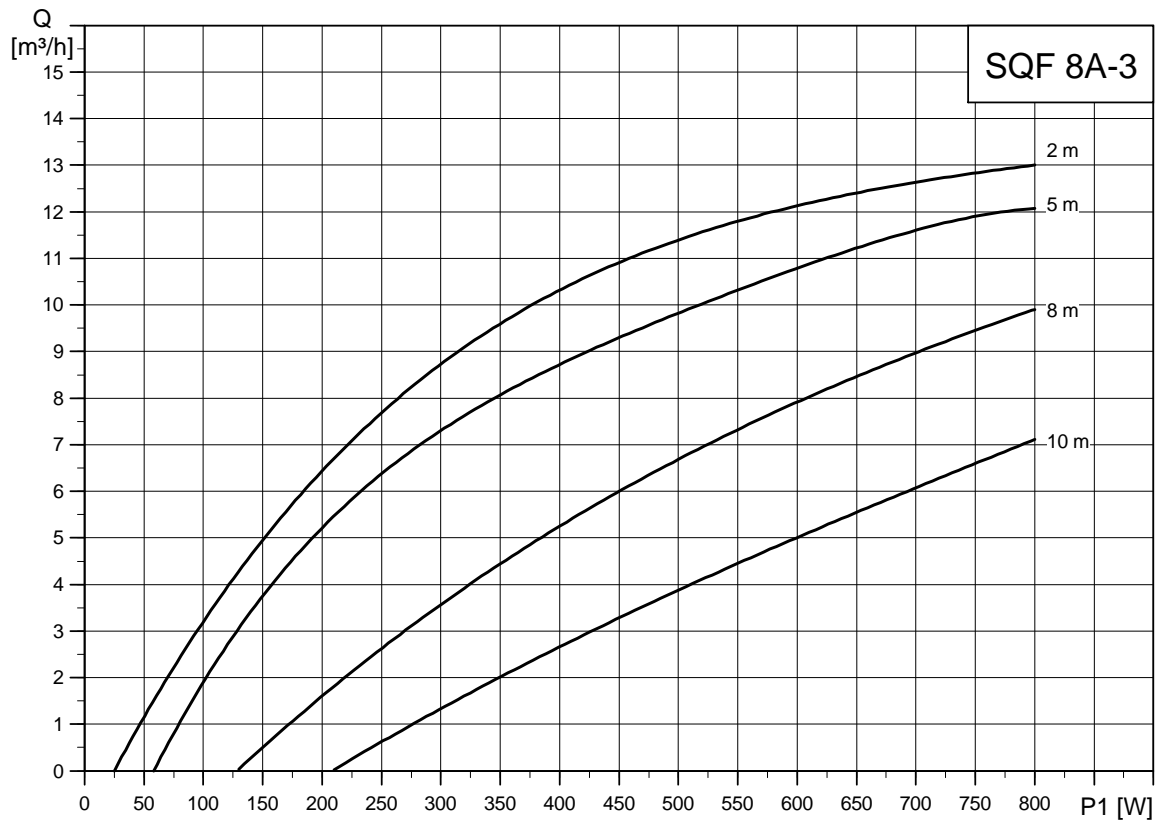

TM02 2343 4101

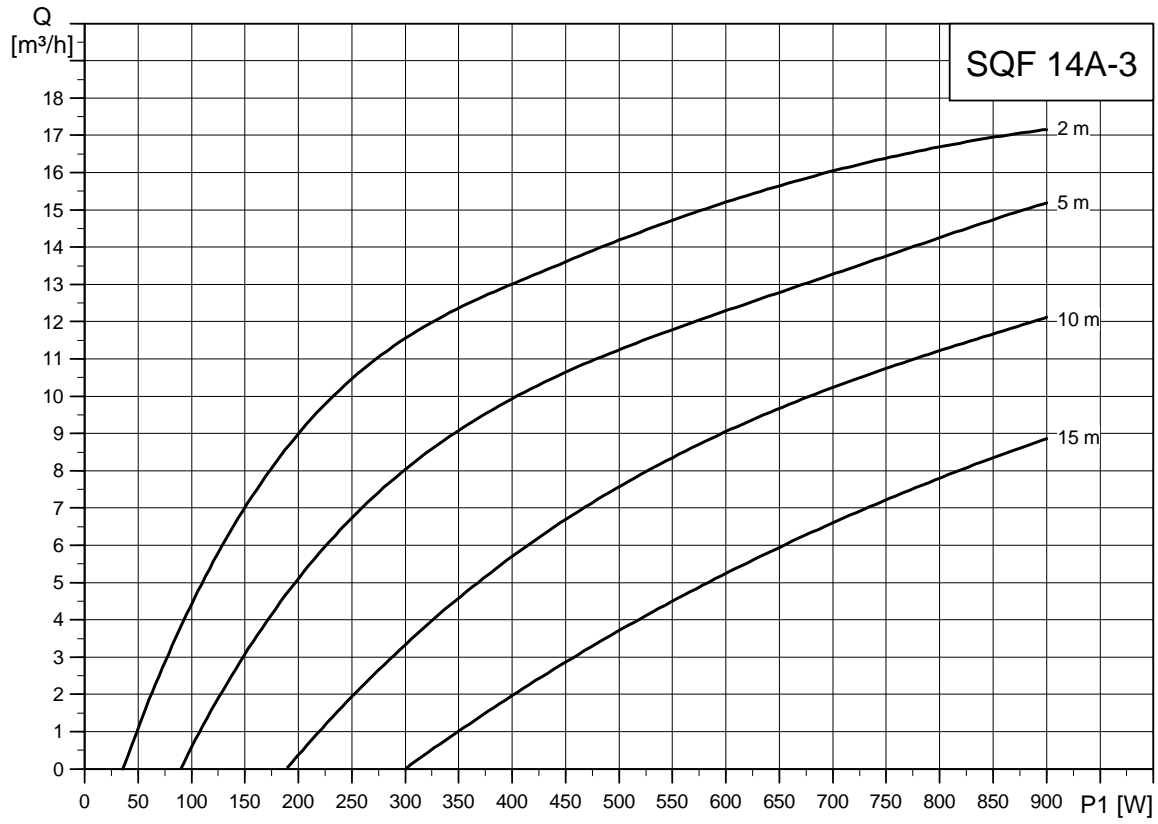

TM02 2344 4101

Dimensions and weights

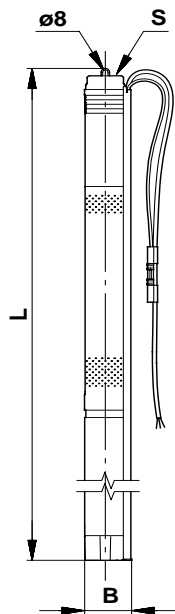

TM02 2209 3901

Pump type	Dimensions [mm]			Net weight [kg]★	Brutto weight [kg]★	Shipping volume [m ³]★
	L	B	S			
SQF 0.6-2 (N)	1185	74	Rp 1½	7.6	9.4	0.02
SQF 1.2-2 (N)	1225	74	Rp 1½	7.9	9.7	0.02
SQF 2.5-2 (N)	1247	74	Rp 1½	8.2	10.0	0.02
SQF 5A-3 (N)	815	101	Rp 1½	8.1	9.6	0.02
SQF 5A-6 (N)	875	101	Rp 1½	8.8	10.3	0.02
SQF 8A-3 (N)	920	101	Rp 2	9.5	11.0	0.02
SQF 14A-3 (N)	975	101	Rp 2	10.9	12.4	0.02

★ Pump complete

Electrical data

30 - 300 VDC or 1 x 90 - 240 VAC, 50/60 Hz

Pump type	Motor type	Max. power input P ₁ [W]	Max. current [A]
SQF 0.6-2 (N)	MSF 3 (N)	900	7
SQF 1.2-2 (N)	MSF 3 (N)	900	7
SQF 2.5-2 (N)	MSF 3 (N)	900	7
SQF 5A-3 (N)	MSF 3 (N)	900	7
SQF 5A-6 (N)	MSF 3 (N)	900	7
SQF 8A-3 (N)	MSF 3 (N)	900	7
SQF 14A-3 (N)	MSF 3 (N)	900	7

SQF pump

Supply to pump	1 x 90 - 240 V $-10\%/+6\%$, 50/60 Hz. 30 - 300 VDC.
Run-up time	Depending on power source.
Start/stop	No limitation to the number of starts/stops per hour.
Enclosure class	IP 68.
Motor protection	Built into the pump. Protection against: - Dry running by means of a water level electrode. - Overvoltage and undervoltage. - Overload. - Overtemperature.
Conductivity	$\geq 70 \mu\text{s/cm}$ (micro siemens).
Sound pressure level	The sound pressure level is lower than the limiting values stated in the EEC Machinery Directive.
Radio noise	SQF comply with EMC Directive 89/336/EEC. Approved according to EN 50081-1 and 50082-2.
Reset function	SQF can be reset via CU 200 or by disconnecting the power from the power supply in 1 minute.
Power factor	PF = 1.
Operation via generator	Voltage: 230 VAC, $-10\%/+6\%$. The generator output must be minimum 1 k VA.
Earth leakage circuit breaker	If the pump is connected to an electrical installation where an earth-leakage circuit breaker (ELCB) is used as an additional protection, this circuit breaker must trip out when earth fault currents with DC content (pulsating DC) occur.
Borehole diameter	SQF 0.6, SQ 1.2, SQF 2.5: Minimum: 76 mm. SQF 5A, SQF 8A, SQF 14A: Minimum: 104 mm.
Installation depth	Min.: The pump must be totally submerged in the pumped liquid. Max.: 150 m below the static water table (15 bar).
Suction strainer	Holes of the suction strainer: SQF 0.6 (N), SQF 1.2 (N), SQF 2.5 (N): $\varnothing 2.3$ mm. SQF 5A: $\varnothing 2.5$ mm. SQF 5A N, SQF 8A (N), SQF 14A (N): 4 mm x 20 mm.
Pumped liquids	pH 5 to 9. Sand content up to 50 g/m ³ .
Marking	CE

IO 100 switch box

Voltage	Max. 225 VDC, 7 A. Max. 265 VAC, 7 A.
Enclosure class	IP 55.
Ambient temperature	In operation: -30°C to $+50^{\circ}\text{C}$; during storage: -30°C to $+60^{\circ}\text{C}$.
Marking	CE

IO 101 switch box

Voltage	230 VAC $-15\%/+10\%$, 50/60 Hz (internal relay). Max. 225 VDC, 7 A Max. 265 VAC, 7 A
Enclosure class	IP 55.
Ambient temperature	In operation: -30°C to $+50^{\circ}\text{C}$; during storage: -30°C to $+60^{\circ}\text{C}$.
Marking	CE

IO 102 breaker box

Voltage	Max. 225 VDC, 7 A. Max. 265 VAC, 7 A.
Enclosure class	IP 55.
Ambient temperature	In operation: -30°C to $+50^{\circ}\text{C}$; during storage: -30°C to $+60^{\circ}\text{C}$.
Marking	CE

CU 200 control unit

Voltage	30 - 300 VDC 90 - 240 VAC.
Power consumption	5 W.
Current consumption	Max. 130 mA.
Enclosure class	IP 55.
Ambient temperature	In operation: -30°C to +50°C; during storage: -30°C to +60°C.
Relative air humidity	95%.
Pump cable	Max. length between CU 200 and pump: 200 m. Max. length between CU 200 and level switch: 500 m.
Back-up fuse	Max.: 10 A.
Radio noise	The CU 200 complies with EMC Directive 89/336/EEC. Approved according to standards EN 55 014 and 55 014-2.
Marking	CE.
Weight	2 kg.

Wiring diagram for pump

Connection of the MSF motor to the power supply must be done according to the wiring diagram shown below.

As the intelligent motor electronics can handle both connection possibilities, it makes no difference how the wires "+" and "-" or "N" and "L" are connected.

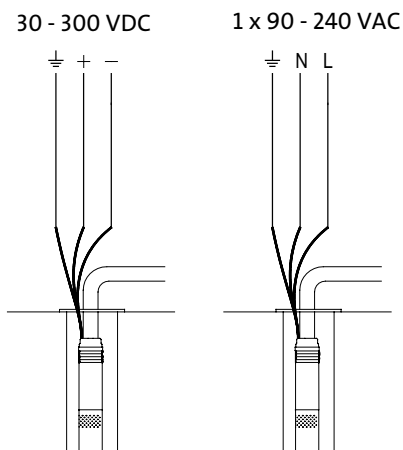

TM02 2437 3901

Material specification - helical rotor pump

Pos.	Description	Material	SQF		SQF-N	
			EN/DIN	AISI	EN/DIN	AISI
1	Valve casing	Polyamide				
1a	Discharge chamber	Stainless steel	1.4301	304	1.4401	316
1d	O-ring	NBR				
2	Valve cup	Polyamide				
3	Valve seat	NBR				
6	Flange, upper	Stainless steel	1.4301	304	1.4401	316
7a	Circlip	Stainless spring steel	1.4310	310	1.4310	310
9	Pump stator	Stainless steel/EPDM	1.4301	304	1.4401	316
13	Pump rotor	Hard-chromed stainless steel	1.4301	304	1.4401	316
16	Torsion shaft	Stainless steel	1.4401	316	1.4401	316
39	Valve spring	Stainless spring steel	1.4406	316 LN	1.4406	316 LN
55	Outer sleeve	Stainless steel	1.4301	304	1.4401	316
70	Valve guide	Polyamide				
	Cable guard	Stainless steel	1.4301	304	1.4401	316
	Screws for cable guard	Stainless steel	1.4401	316	1.4401	316

Example: SQF 1.2-2

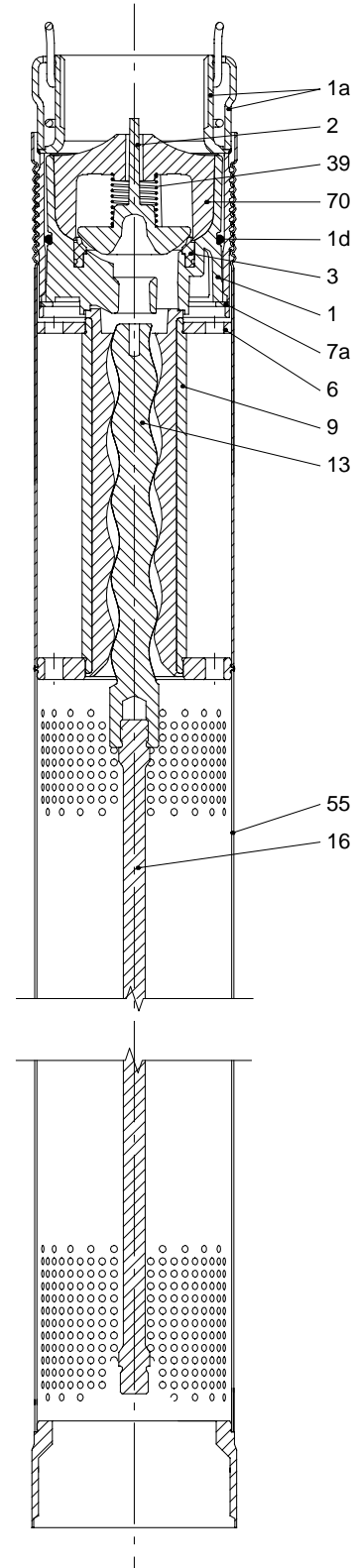

TM02 2213 3901

Material specification - centrifugal pump

Pos.	Description	Material	SQF		SQF-N	
			EN/DIN	AISI	EN/DIN	AISI
1	Valve casing	Stainless steel	1.4301	304	1.4401	316
4	Chamber, upper	Stainless steel	1.4301	304	1.4401	316
6	Top bearing	NBR				
7	Neck ring	NBR/PPS				
8	Bearing	NBR				
9	Chamber, complete	Stainless steel	1.4301	304	1.4401	316
11	Nut for split cone	Stainless steel	1.4301	304	1.4401	316
12	Split cone	Stainless steel	1.4301	304	1.4401	316
13	Impeller	Stainless steel	1.4301	304	1.4401	316
14	Inlet part	Stainless steel	1.4301	304	1.4401	316
14a	Connecting piece, complete (MSF 3 adapter)	Stainless steel	1.4301	304	1.4401	316
15	Strainer	Stainless steel	1.4301	304	1.4401	316
16	Shaft, cylindrical	Stainless steel	1.4057	431	1.4460	329
17	Strap	Stainless steel	1.4301	304	1.4401	316
18	Cable guard, pump	Stainless steel	1.4301	304	1.4401	316
18c	Cable guard, motor	Stainless steel	1.4301	304	1.4401	316
19	Nut for strap	Stainless steel	1.4301	304	1.4401	316
19a	Nut	Stainless steel	1.4401	316	1.4401	316
24	Coupling with nut	Stainless steel	1.4462	329	1.4462	329
24a	Supporting ring	Stainless steel	1.4401	316	1.4401	316
24b	Spline protector	NBR				
25	Retainer for neck ring, complete	Stainless steel	1.4301	304	1.4401	316
85	Stop ring Only SQF 5A and SQF 14A	Carbon/graphite PTFE				
	Screws for cable guard	Stainless steel	1.4401	316	1.4401	316

Example: SQF 14A-3

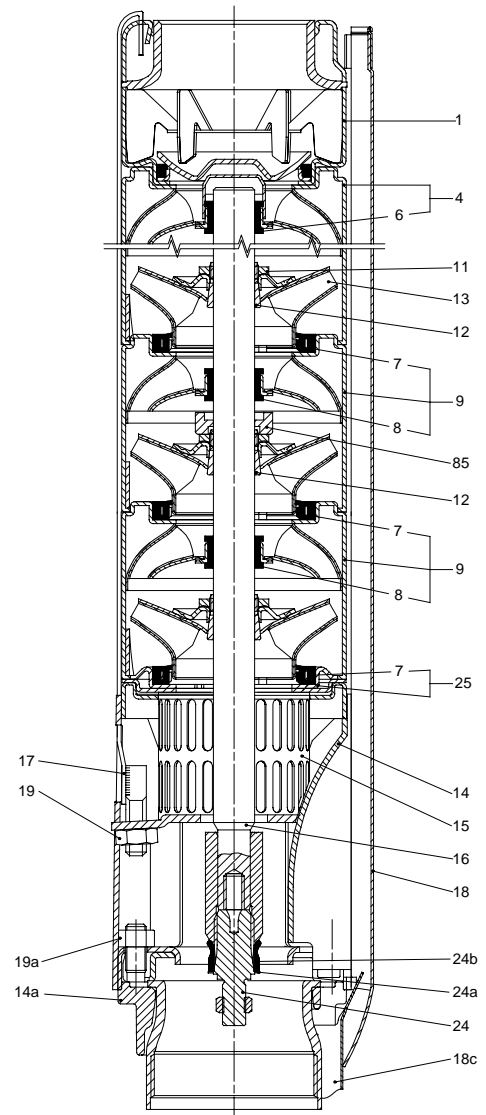

TM02 2439 4301

Material specification - motor

Pos.	Description	Material	MFS 3		MFS 3 N	
			EN/ DIN	AISI	EN/ DIN	AISI
201	Stator with sleeve, complete	Stainless steel	1.4301	304	1.4401	316
202	Rotor	Stainless steel	1.4301	304	1.4401	316
202a	Stop ring	PP				
202c	Shaft end	Stainless steel	1.4401	316	1.4401	316
203	Thrust bearing, stationary	Stainless steel/carbon	1.4401	316	1.4401	316
205	Bearing plate with radial bearing	Silicon carbide	1.4301	304	1.4401	316
206	Thrust bearing, rotating	Stainless steel/ aluminium oxide Al ₂ O ₃	1.4401	316	1.4401	316
220	Motor cable with plug					
222a	Filling plug	NBR				
223	Electronic unit					
224	O-ring	Standard version: NBR. N version: FKM.				
225	Top cover	PPS				
232	Shaft seal	MFS 3: NBR. MFS 3 N: FKM.				
243	Thrust-bearing housing	Stainless steel	1.4408	316	1.4408	316
250	Nut (M4)	Stainless steel	1.4401	316	1.4401	316

MFS 3

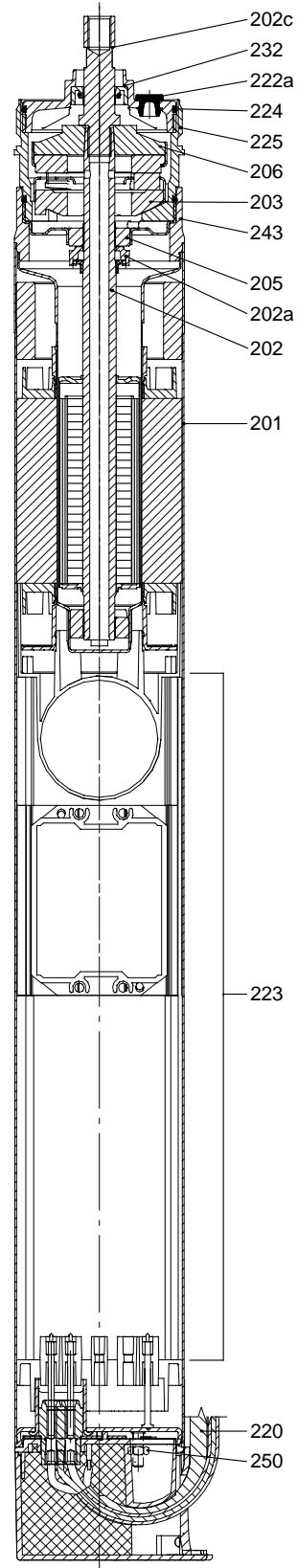

TM02 2215 3901

Complete unit with 2 m cable

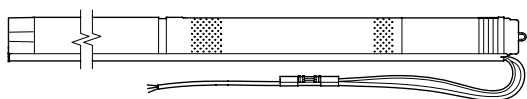

TM02 2217 3901

Pump type	Pump size	Product no.	
		SQF	SQF-N
SQF 0.6-2 (N)	3"	96 07 80 21	96 07 80 22
SQF 1.2-2 (N)	3"	96 07 80 23	96 07 80 24
SQF 2.5-2 (N)	3"	96 07 80 25	96 07 80 26
SQF 5A-3 (N)	4"	96 07 80 34	96 07 80 35
SQF 5A-6 (N)	4"	96 07 80 36	96 07 80 37
SQF 8A-3 (N)	4"	96 07 80 38	96 07 80 39
SQF 14A-3 (N)	4"	96 07 81 37	96 07 81 38

Pump without motor

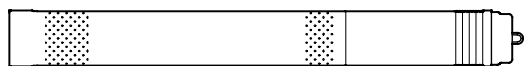

TM02 2218 3901 - TM02 2221 3901

Pump type	Pump size	Product no.	
		SQF	SQF-N
SQF 0.6-2 (N)	3"	96 07 80 12	96 07 80 13
SQF 1.2-2 (N)	3"	96 07 80 14	96 07 80 15
SQF 2.5-2 (N)	3"	96 07 80 16	96 07 80 17
SQF 5A-3 (N)	4"	96 07 81 09	96 07 81 10
SQF 5A-6 (N)	4"	96 07 81 11	96 07 81 12
SQF 8A-3 (N)	4"	96 07 81 13	96 07 81 14
SQF 14A-3 (N)	4"	96 07 81 33	96 07 81 34

Motor without pump

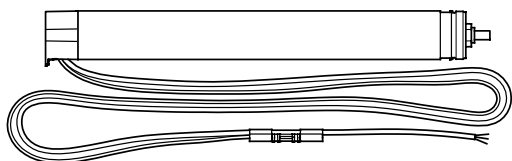

TM02 2219 3901

Motor type	Power P ₁ [W]	Max. current [A]	Product no.
MSF 3	900	7	96 04 09 89
MSF 3 N			96 04 09 90

Submersible drop cables

The submersible drop cables for SQF pumps are approved for use in drinking water (KTW approved). The material of the submersible drop cable is EPR.

The table below shows the maximum length of the submersible drop cable for the different sizes of cross-section of the leads according to a 2% power loss.

GF 50

No. of 50 Wp solar modules	Power [Wp]	Max. cable length [m]			
		1.5 mm ²	2.5 mm ²	4.0 mm ²	6.0 mm ²
3	150	140	234	377	560
4	200	105	176	280	420
6	300	70	117	187	280
8	400	52	88	140	210
10	500	42	70	112	168
12	600	35	58	93	140
14	700	30	50	80	120
16	800	25	40	70	105
18	900	23	39	62	90
20	1000	21	35	56	84

The values in the table are based on Grundfos 50 W solar modules (156 VDC output).

The table values are calculated on the basis of the formula:

$$L = \frac{\Delta P \times q \times V_{mp}^2}{Wp \times 100 \times 2 \times \rho} [m]$$

where

L = Length of cable [m]

ΔP = Power loss [%]

V_{mp} = Maximum power voltage [V]

Wp = Watt peak [Wp]

ρ = Specific resistance: 0.0173 [Ω mm²/m]

q = Cross-section of submersible drop cable [mm²]

The sizing tool in WinCAPS makes it possible to calculate the exact losses.

IO 100

Product	Product no.
IO 100	96 47 50 73

IO 101

Product	Product no.
IO 101	96 47 50 74

CU 200

Product	Product no.
CU 200	96 46 78 01

IO 102

Description	Product no.
IO 102 breaker box for wind turbine.	96 47 50 65

Wind turbine H80 Whisper



TM02 7886 4403

Description	Product no.
Wind turbine H80 Whisper.	96 47 21 20
Instructions are included.	

Specifications

Rotor diameter:	3.0 metres
Weight:	30 kg
Mount:	2.5" Schedule 40
Start-up wind speed:	3.1 m/sec.

Tower kit for H80 Whisper

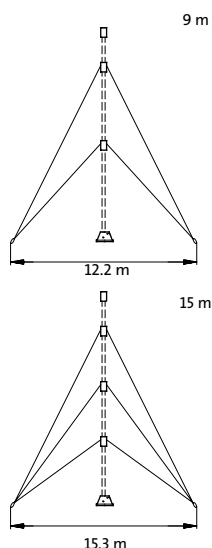

TM02.5882.3502

Description	Height	Product no.
Tower kit for H80 Whisper	9 m	96 47 50 66
	15 m	96 47 50 67

Instructions are included.

Note: The pipes are not included

For tower pipe selection see below.

Tower installation kit

Description	Product no.
Tower installation kit.	96 47 50 69

Note: The gin pole is not included

For tower pipe selection see below.

Tower pipe selection

The tower kit is designed to use 2½" pipes (outside diameter of 73 mm).

The following table shows the required thickness of the pipe(s) depending on the maximum wind speed:

Max. wind speed [m/s]	Recommended wall thickness [mm]
35	2.3
40	3.0
50	3.6

The wall thickness of the gin pole must be 1.6 mm or greater.

Pieces of pipe needed:

Tower kit, 9 m

- 1 pipe of 4.0 m for tower
- 1 pipe of 5.2 m for tower
- 1 pipe of 4.6 m for gin pole.

Tower kit, 15 m

- 2 pipes of 4.6 m for tower
 - 1 pipe of 6.1 m for tower
- 1 pipe of 5.8 m for gin pole.

Auger / anchor

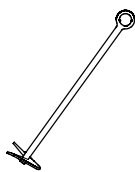

TM02 2571 4501

Description	Length [m]	Product no.
Auger /anchor (4 pcs.)	1.2	96 47 50 68

Grease

Description	Product no.
Grease for lubrication of motor shaft.	96 03 75 62

Level switch



TM02 2407 4201

Description	Product no.
Level switch.	00 01 07 48
High water level: Contact is closed. Low water level: Contact is open.	

Anemometer



CR 7667

Description	Product no.
<p>The anemometer enables the measurement of</p> <ul style="list-style-type: none"> the current wind speed (in m/sec., knots, mph or Beaufort) the average wind speed (in m/sec., knots, mph or Beaufort) the current temperature in degrees celsius [°C] or degrees Fahrenheit [°F] the chill factor. <p>The anemometer is</p> <ul style="list-style-type: none"> waterproof down to 10 metres programmable. <p>Dimensions: 10 x 4 x 1 cm Weight: 42 g.</p>	96 49 66 85

Submersible drop cable



TM00 7882 2296

Description	Version	Diameter [mm]	Product no.
3-core cable, incl. earth conductor. KTW approved. When ordering, please state length [m].	3G 1.5 mm ² (round)	9.6 - 12.5	ID 79 46
	3G 2.5 mm ² (round)	11.5 - 14.5	ID 79 47
	3G 4.0 mm ² (round)	13.0 - 16.0	ID 79 48
	3G 6.0 mm ² (round)	14.5 - 20.0	RM 40 98
	3G x 1.5 mm ² (flat)	6.5 - 13.2	RM 39 52

Cable termination kit, type KM

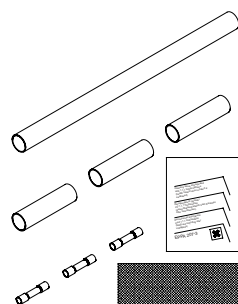

TM00 3838 1294

Description	Cross section of leads [mm ²]	Product no.
For watertight shrink-joining of motor cable and submersible drop cable (round or flat cable).		
Enables the joining of:		
- cables of equal size	1.5 - 2.5	96 02 14 62
- cables of different size	4.0 - 6.0	96 02 14 73
- cable leads with single leads.		
The joint is ready for use after a few minutes and requires no long hardening time as do resin joints.		
The joint cannot be separated.		

Cable clips



TM00 4179 1994

Description	Dimensions	Product no.
For fastening of cable and straining wire to the riser pipe.		
The clips should be fitted every 3 metres. One set for approx. 45 m riser pipe.	Length = 7,5 m 16 buttons	00 11 50 16

Straining wire



TM00 7897 2296

Description	Diameter	Product no.
Stainless steel EN/DIN 1.4401. Retains the submersible pump. When ordering, please state length [m].	2 mm	00 ID 89 57

Wire clamp



TM00 7898 2296

Description	Description	Product no.
Stainless steel EN/DIN 1.4401.	Two clamps per loop	00 ID 89 60

96 47 78 03 11 03	GB
Repl. 96 47 78 03 09 02	

Subject to alterations.